

RCPORT-TD400/410/420

USER MANUAL

V 1.0.2

CHIPSEN

RCPORT- TD400/410/420 User Manual LIST

RCPORT- TD400/410/420 USER MANUAL LIST	2
1. DOUCUMENT OVERVIEW	3
2. PRODUCT OVERVIEW	3
3. RCPORT-TD STATE	4
4. PC SETUP PROGRAM	5
5. EXTERNAL INTERFACE	6
5.1. OPERATION SWITCH.....	7
5.2. BAUD-RATE DIAL.....	7
5.3. DEVICE SELECTION DIAL	7
5.4. RESET SWITCH	7
5.5. CONNECT LED.....	8
6. DATA TRANSMIT	9
6.1. SLAVE ROLE.....	9
6.2. MASTER ROLE.....	9
5.2.1. <i>Device Selection Dial is set to '1(A)' to '7'</i>	9
5.2.2. <i>Device Selection Dial is set to 'M'</i>	9
7. SUPPLEMENT	11
7.1. SPECIFICATION	11
7.2. LIMITATIONS OF LIABILITY AND LEGAL NOTICE.....	12

1. Document Overview

This document describes the operation and use of the "CHIPSEN RCPORT-TD400/410/420 Product" (hereinafter referred to as "RCPORT-TD").

2. Product Overview

- Function
 - The RCPORT-TD enables master and slave role operations through operation switch settings
 - The RCPORT-TD enables wireless serial communication through a communication dial.
 - The RCPORT-TD enables wireless serial communication with a registered device through a device selection dial.
- Communication Method
 - The RCPORT-TD transmits data input to the serial port bypass to the connected Remote device. Conversely, the data received from the Remote device is also output bypass to the serial port.
 - When high-speed/continuous data is communicated, RCPORT-TD may cause errors, including data omission, due to Bluetooth radio quality, performance, and usage environment. In this case, it is necessary to review the problem solving method for the use and test environment through technical support. (Technical Support : s1@chipsen.com or tech@chipsen.com)
 - By default, RCPORT-TD operates as a serial communication setting, and if you want to change the serial communication setting, you can change it using the PC setting program provided. The default serial communication settings are as follows

< Default Serial Communication Settings >

- Communication method: According to the settings of the Serial interface dial
- Baud rate: 9600bps
- Data bit : 8
- Parity bit: None
- Stop bit : 1

- Operation Role
 - Slave role : It waits for the connection of the Remote device.
 - Master role : It can scan and connect Chipsen's Bluetooth Low Energy Products (RCPORT-TD4/TD5 Series , BoT-nLE/TMA Series) and the PC Setup program can scan and connect multiple Slave devices.

- Certification
 - **KC(with EMC)**
 - **CE RED & DOC(with RoHS)**
 - **FCC**
 - **TELEC**
 - **SIG:**

3. RCPORT-TD State

- RCORT-TD is divided into a Connected state and a Disconnect state depending on the connection and communication status with the other device, and there is also a Setting state for user settings for RCORT-TD.
- Setting State
 - You can use the PC Setup program to change the default settings (renaming the device) or check the default information (version, device name, etc.)
 - Using a PC setting program, it searches for and registers connectable devices. If the RCPORT-TD exits the setting state and becomes the Master Role, try to connect to the registered device.
- Disconnect State
 - No connection to remote device during Master or Slave role
 - Slave role: Stay connected until the power is off or the other device is connected.
 - Master role : Try the connection until connected to the Remote device.

** Use the PC setup program to register the device or set the device selection dial to 1(A) to auto-pairing to the nearest Slave role's device. If neither, wait without a connection action because there is no device to connect to.
- Connected State
 - Connection to remote device during Master or Slave role
 - Master role : If the **device selection dial** is set to 'M', try to connect until connected to all registered devices

4. PC Setup program

- PC Setup program is provided to check device information, change serial communication settings, scan/connect devices. The PC Setup program can be downloaded from our website (<https://www.chipsen.com>)
- To use a PC Setup program, RCPORT-TD's **serial interface dial** must be selected as Set and connected to the PC.

*The English version of the program will be updated soon.

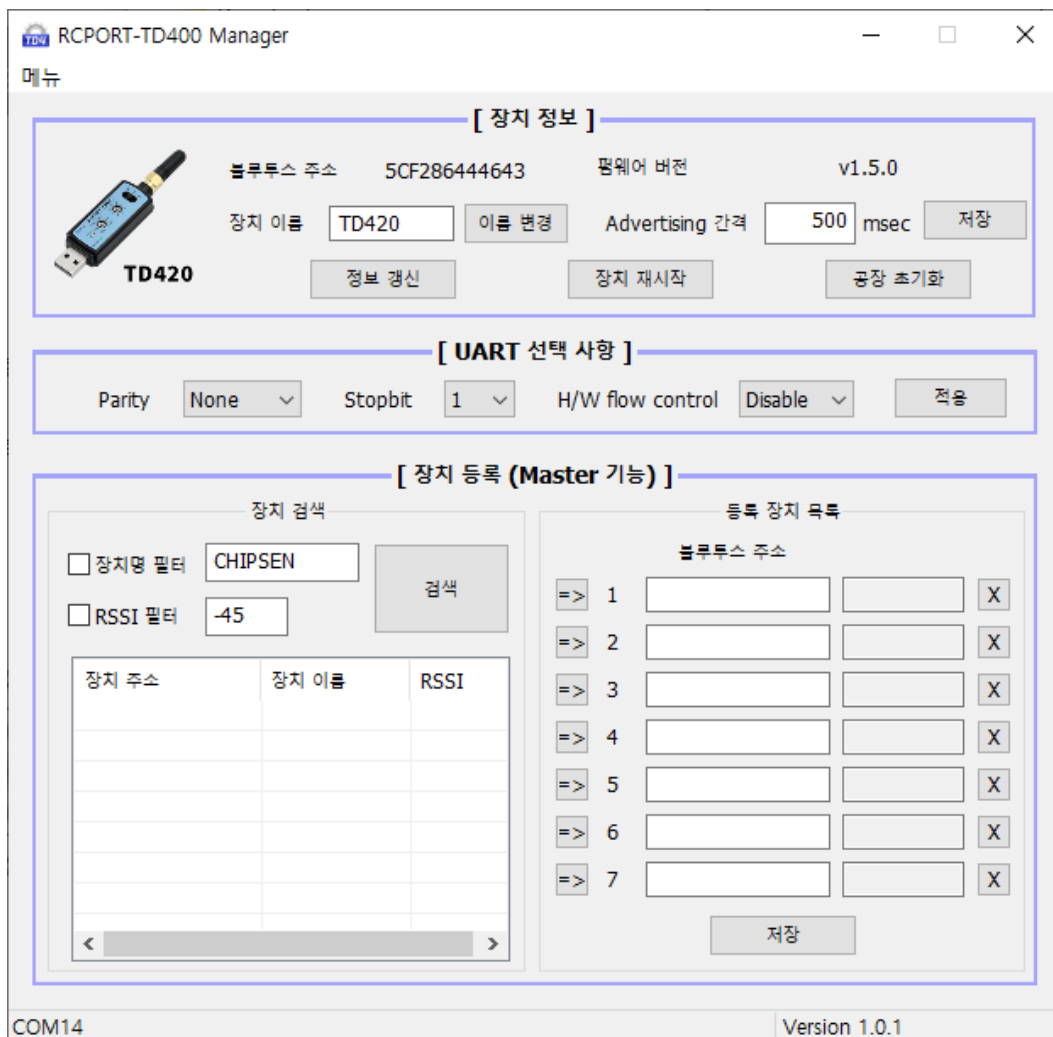

<PC Setup Program(Korean version) image>

5. External interface

- The RCPORT-TD operates through a Baud-rate dial, a device selection dial, and an operation switch.
- The status of RCPORT-TD can be checked through the connection LED that informs the connection status, and the TX/RX LED that displays data transmission and reception through the serial port.
- Press Reset switch to initialize RCPORT-TD.

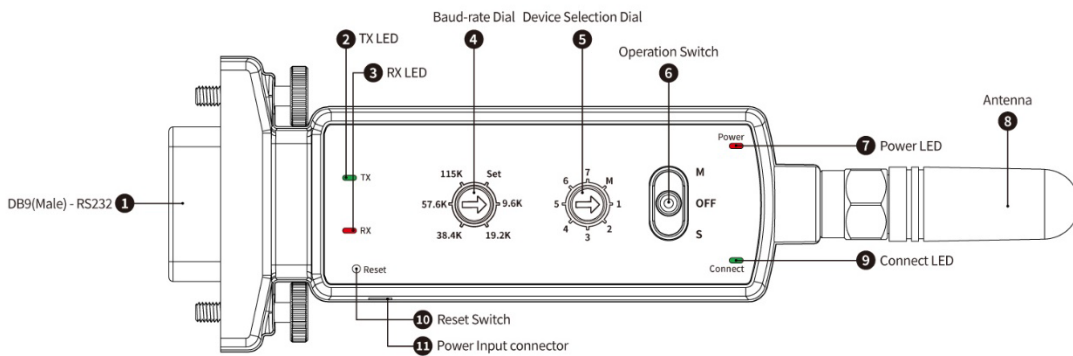

<RCPORT-TD400/410 External interface>

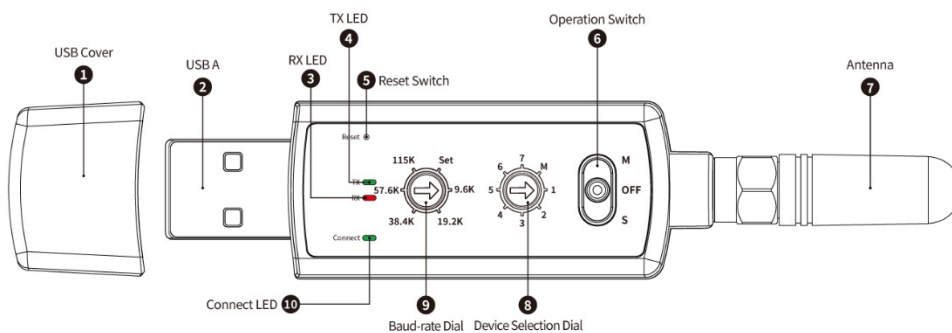

<RCPORT-TD420 External interface>

5.1. Operation Switch

- Power off the RCPORT-TD or set the Operation Role (Master or Slave)
- Off : The RCPORT-TD is powered off.
- M : Set Master role, Try the connection until connected to the Remote device.
- S : Set Slave role, Stay connected until the power is off or the other device is connected.

5.2. Baud-rate Dial

- Sets the Baud-rate for the RCPORT-TD.
- If **Boad-rate Dial** is set to 'Set', wireless communication operation is stopped and it can be loaded into the PC setup program.
- If **Serial Interface Dial** is changed, the RCPORT-TD reboots to the changed value.

5.3. Device Selection Dial

- If operation switch of the RCPORT-TD is placed in the 'M' position, device selection dial is performed and It can be used in three ways. if the operation switch is placed in the 'S' position, the device selection dial does not have a separate function and waits for the connection of the other device equally.
- **1:1 Auto Pairing** : Set the **device selection dial** to 1(A). It then connects to the nearest slave device. * This is only possible if there is no device registered in SLOT 1 through the PC setup program beforehand. Press the RESET button and use it if you do not know whether you are registered or not.
- **1:1 Node Switching** : If you set the **device selection dial** to one of 1~7, connect it to a preregistered device for each number(slot).*Device registration is only possible through the PC setup program.
- **1:7 Multi Connect** : If you set the **device selection dial** to one of 1~7, connect it to a preregistered device for each number(slot).*Device registration is only possible through the PC setup program

5.4. RESET Switch

- Initialize the state of the RCPORT-TD. If the switch is pressed and removed, all settings are initialized immediately.
- Press reset button and RCPORT-TD automatically restarts.

5.5. Connect LED

- Displays the operational status of the RCPORT-TD
- Set
 - 'The connection LED flashes quickly if Serial Interface Dial is set to 'Set'.

*See the picture below

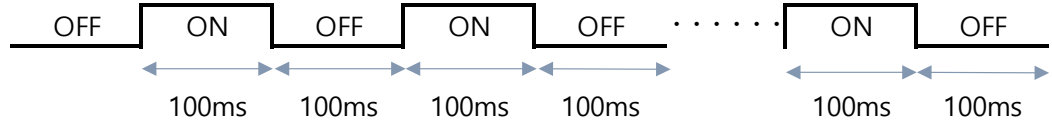

- Connected
 - The Connect LED continues to illuminate while the RCPORT-TD is connected to the Remote Device.

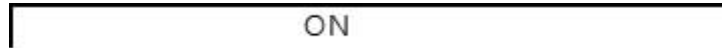

- Disconnected
 - The Connect LED continues to flicker if the RCPORT-TD is not connected to the Remote Device.

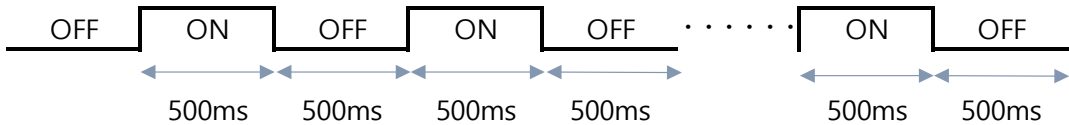

6. Data transmit

6.1. Slave Role

If RCPORT-TD is connected to the Remote Device, all data are sent bypass when it is sent or received.

Status	If RCPORT-TD is connected to the Remote Device
Sent example	(HOST→RCPORT-TD) : ABCD<CR> (Remote Device) : ABCD<CR>
Received example	(Remote Device) : EFGH<CR> (RCPORT-TD→HOST) : EFGH<CR>

Data may be divided or delayed depending on the connected remote device and serial port transmission speed (Baudrate)..

6.2. Master Role

if RCPORT-TD is connected to the Remote Device, all data are sent bypass when it is sent or received. However, if you are connected to multiple connecting devices, you must use user data protocols to distinguish between each data because it may be necessary to distinguish between them.

5.2.1. Device Selection Dial is set to '1(A)' to '7'

RCPORT-TD connect to a preregistered device for each number(slot). If you are not pre-registered, set it to 1(A) and connect with the nearest 1 Slave Device. all data are sent bypass when it is sent or received. *Device registration is only possible through the PC setup program.

Status	If RCPORT-TD is connected to one remote device.
Sent example	(HOST→RCPORT-TD) : ABCD<CR> (Remote Device) : ABCD<CR>
Received example	(Remote Device) : EFGH<CR> (HOST→RCPORT-TD) : EFGH<CR>

5.2.2. Device Selection Dial is set to 'M'

RCPORT-TD connect to a preregistered device for all number(slot). all data are sent bypass when it is sent or received. *Device registration is only possible through the PC





setup program.

However, if you are connected to multiple connecting devices, you must use user data protocols to distinguish between each data because it may be necessary to distinguish between them.

Status	If RCORT-TD is connected to multiple remote devices.
Sent example	(HOST→RCPORT-TD) : ABCD<CR> (Conncted Remote Device-01→HOST) : ABCD<CR> (Conncted Remote Device -02→HOST) : ABCD<CR> (Conncted Remote Device -03→HOST) : ABCD<CR>
Received example	(HOST→ Conncted Remote Device -01) : ABCD<CR> (HOST→ Conncted Remote Device -02) : EFGH (HOST→ Conncted Remote Device -03) : 1234<CR> (RCPORT-TD→HOST) : ABCD<CR> EFGH1234<CR>

7. Supplement

7.1. Specification

Model	RCPORT-TD400	RCPORT-TD410	RCPORT-TD420	RCPORT-TD450
Pictures				
Network Connectivity	Bluetooth Low Energy 5.2			
Ports	RS232		Virtual Serial	RS 422/485
Connector	D-SUB9 (F)		USB-A	D-SUB9 (M)
Transmit Power (TX Power)	Max. +20 dBm			
Transmission Distance	1,000ft with default antenna			
Configuration UI	-Baud Rate Dial -Device Selection Dial -Operation Switch			-Serial Interface Dial -Device Selection Dial -Operation Switch
Input Voltage	DC 5 ~ 24V		DC 5V	DC 5 ~ 24V
Battery	-	Built-in	-	-
Operating Temperature	-20 ~ 85°C	-20 ~ 60°C	-20 ~ 85°C	
Operating Humidity	0 ~ 85%			
Dimensions (mm) without Ant	80.3 × 34.3 × 23.7	80.3 × 34.3 × 23.7	70 × 21.6 × 14.3	80.3 × 34.3 × 17.4
Max. Connect Devices	Up to 7			
Operating Role	Master / Slave			
Usage	1:1 Auto Pairing / 1:1 Node Switching / 1:7 Multi Connection			
Default Antenna	+1 dBi			
Baud Rate	9,600 ~ 115,200 bps			
Receiving Sensitivity	-98 dBm			
Certifications	SIG, KC, CE, FCC, JAPAN MIC			

7.2. Limitations of Liability and Legal Notice

- This product may cause radio confusion during use and may receive harmful interference from other devices. Therefore, there may be data transfer delays or losses, and users are advised to take this into consideration and use it after sufficient testing. Due to the nature of the radio, there is no guarantee of accuracy, reliability or completeness, nor is there any responsibility. In no event shall Chipsen Co.,Ltd. or Seller's liability limit exceed the paid selling price of the product
- This product is not a "customized" product, but operates on the form, behavior, and software specified by Chipsen Co., Ltd. In other words, be aware that the product is not designed for your specific environment and use it. We recommend that you refer to the functions and commands provided in the manual. It is recommended that you use it after sufficient testing if you use it in a specific environment, and the use and application of this product is entirely with the user (customer) and Chipsen Co., Ltd. has no warranty and no liability.
- The technical information provided in this document describes the representative characteristics of the product and examples of the application circuit. This does not mean allowing industrial property rights, intellectual property rights, or other rights.
- This product and related everything are subject to change without prior notice to improve performance.
- The technical information provided in this document describes the representative characteristics of the product and examples of the application circuit. This does not mean allowing industrial property rights, intellectual property rights, or other rights.
- Chipsen and Chipsen logo is a trademark of Chipsen Co., Ltd. All other brands and product names mentioned in this User's Guide are trademarks of their respective owners.